

Poussoir / Drücker / Pusher A & B

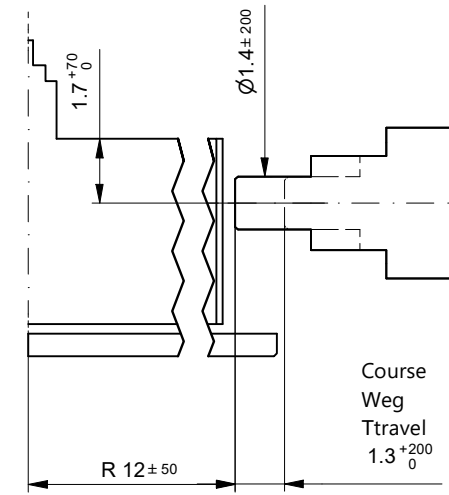

L'angle indiqué pour la direction du poussoir et la position doivent être respectés. pour un autre angle des poussoirs A et B, voir plan 5000.384.

Der angegebene Winkel für die Drückerrichtung und die Position müssen eingehalten werden. Für weitere Drückerwinkel A und B, siehe Zeichnung 5000.384.

The indicated angle of the pusher direction and the position must be fulfilled. For further angles of the pusher A and B, see drawing 5000.384.

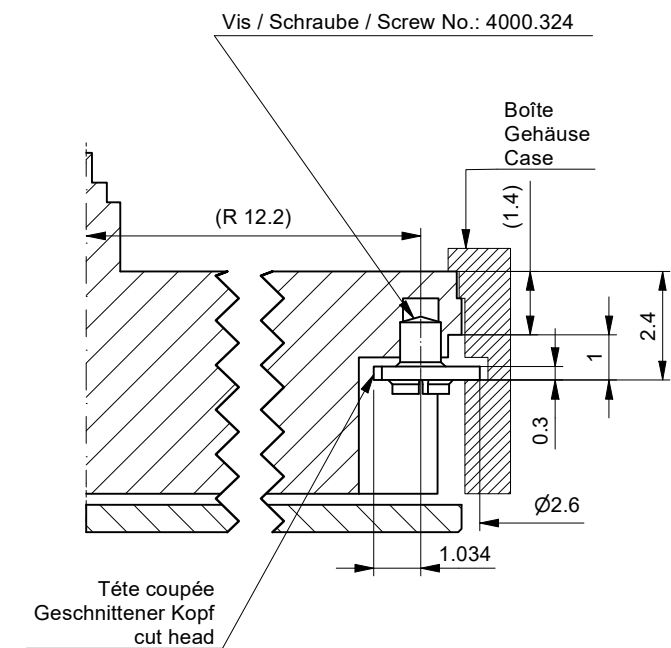
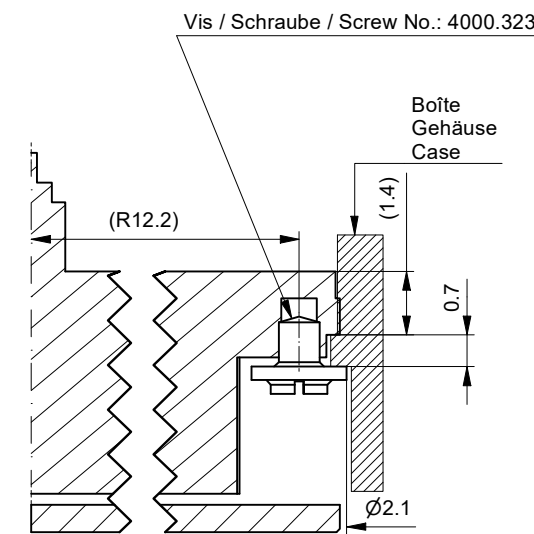

Sécurité entre l'aiguille des seconde et le verre : min. 0.30 mm
Sicherheit zwischen Sekundenzeiger und Glas : min. 0.30 mm
Security between second hand and glass : min. 0.30 mm

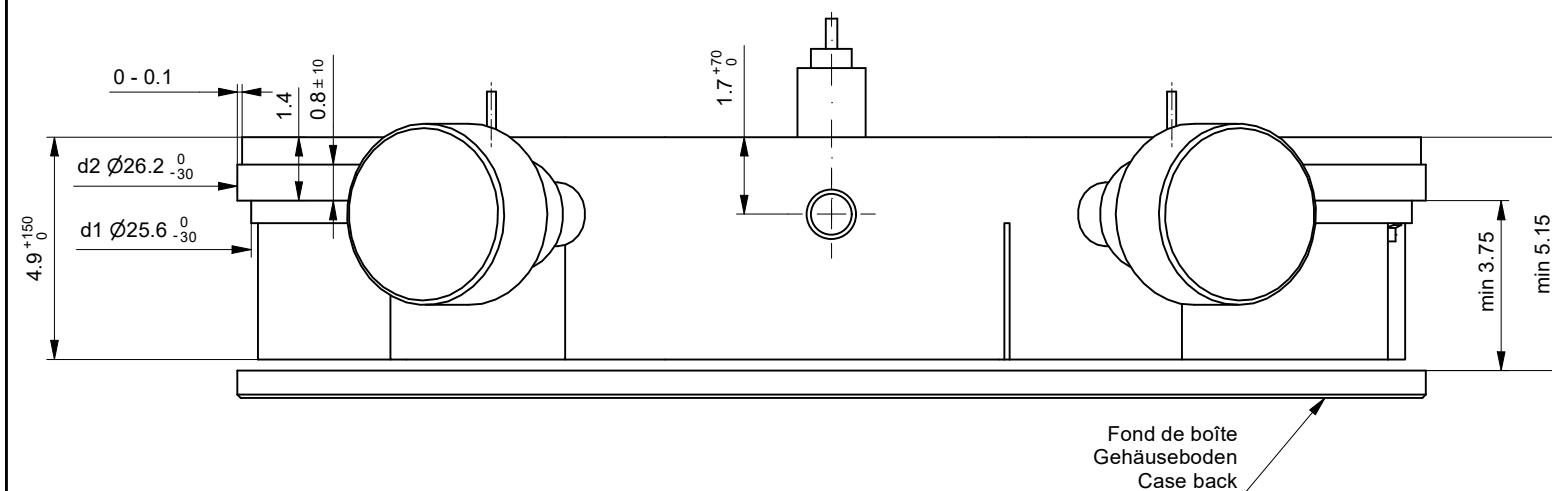

Cage
Uhrwerkgestell 11½" X 10½"
Frame

RONDA 3540.D

Issued	04.05.2009	mg5227
Modified	11.05.2022	dh5221
Released	YES	
Mod. No.	45221	
Tolerance	±20 µm	
Scale	6:1	Page 1 / 1 A3

Sous réserve de modifications Aenderungen vorbehalten Modifications reserved		
No.	5000.383	02

Angle Winkel Angle	30°	
Ø Dp	b	
1.00	11.95	
1.10	11.95	
1.20	11.95	
1.30	11.95	
1.40	11.95	

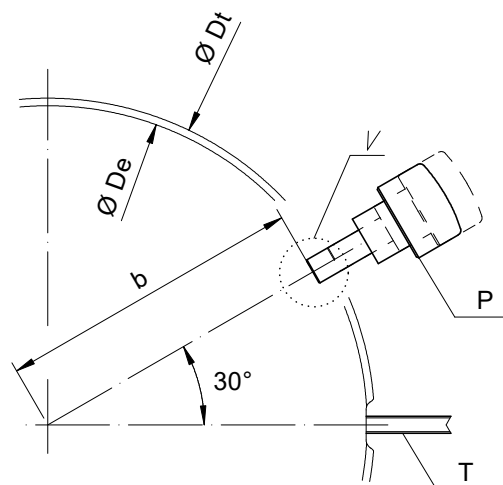

Detail V

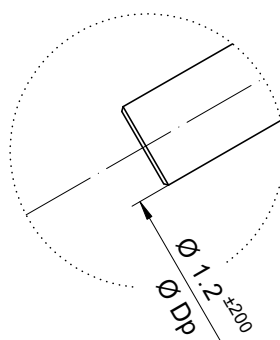

Angle Winkel Angle	0°	
Ø Dp	a	b
1.10	5.92	10.51
1.20	5.97	10.48

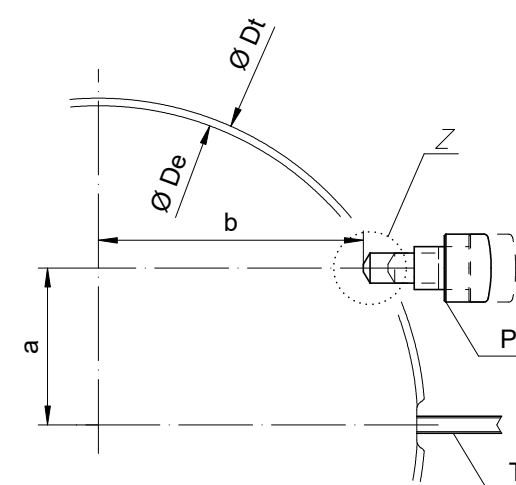

Detail Z

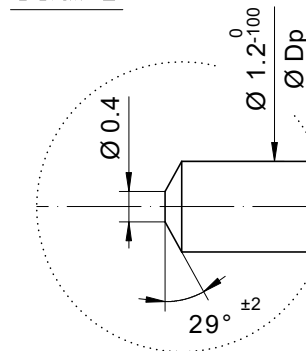

Angle Winkel Angle	20°	
Ø Dp	a	b
1.10	1.94	11.84
1.20	1.99	11.84

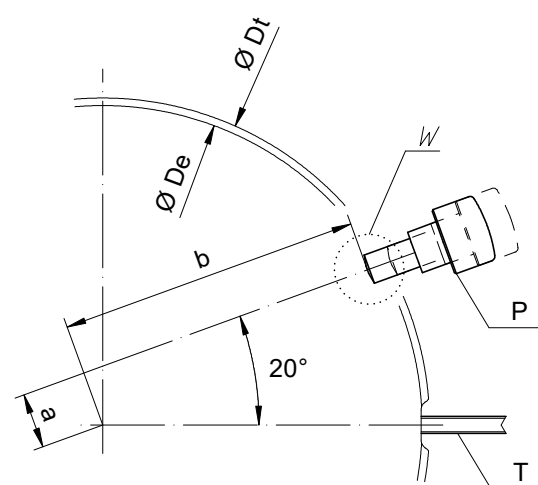

Detail W

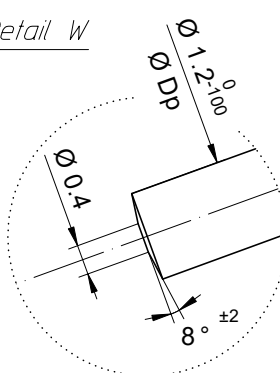

Ø De: diamètre d'encageage
Durchmesser der Gehäusepassung
fitting-diameter

Ø Dp: diamètre du poussoir
Drückerdurchmesser
pusher-diameter

Ø Dt: diamètre total
Totaldurchmesser
total-diameter

P: poussoir en position poussée
Drücker in gedrückter Stellung
pusher in pressed position

T: tige de mise à l'heure
Stellwelle
stem

Angle Winkel Angle	15°	
Ø Dp	a	b
1.10	2.97	11.64
1.20	3.02	11.63

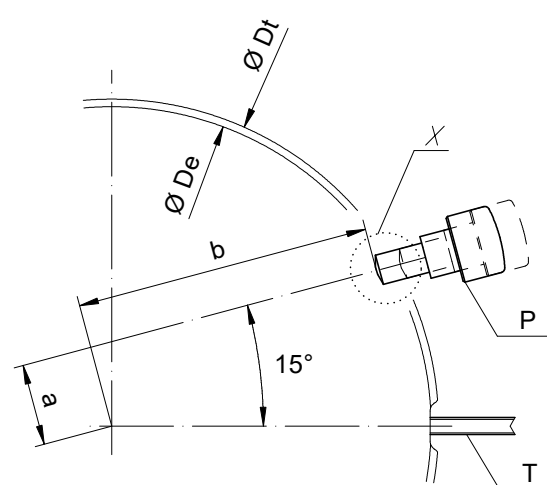

Detail X

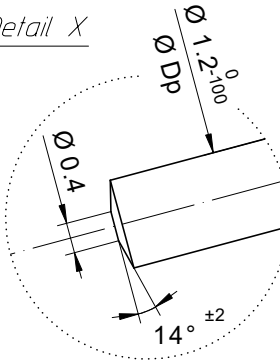

Angle Winkel Angle	10°	
Ø Dp	a	b
1.10	3.98	11.35
1.20	4.03	11.33

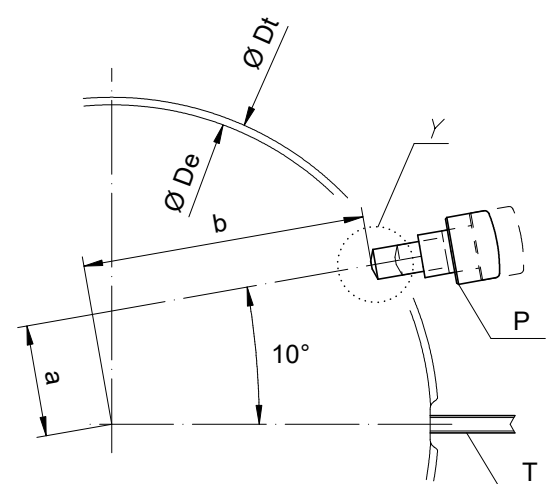

Detail Y

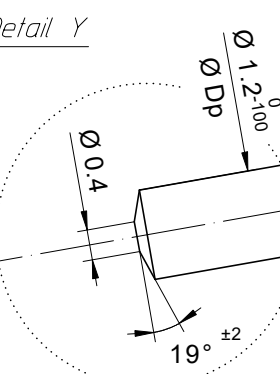

Angle des poussoirs A et B
Winkel der Drücker A und B
Angle of pusher A and B

RONDA 35xx.x

Issued	02 Feb 2010	mK
Modified	03 Feb 2011 ÄA 6970	mK
Released	YES	
Tolerance	+/- 20 µm	
Scale	2.5 : 1 (10 : 1) (A3H)	
Sous réserve de modifications Änderungen vorbehalten Modifications reserved		
No.	5000.384	00