

Sécurité entre l'aiguille des secondes et le verre:  
Sicherheit zwischen Sekundenzeiger und Glas: 0.30mm  
Security between second hand and glass:

Le cadran doit être tenu par la boîte  
Das Zifferblatt muss durch die Schale gehalten werden  
The dial must be hold by the case

La course du poussoir doit être limitée dans le poussoir lui-même. Sa position poussée doit être contrôlée.

Die Weglänge des Drückers ist im Drücker selbst zu begrenzen. In der gedrückten Stellung ist seine Position zu kontrollieren

The way of the pusher has to be limited in the pusher itself. Its position must be checked while pushed in.

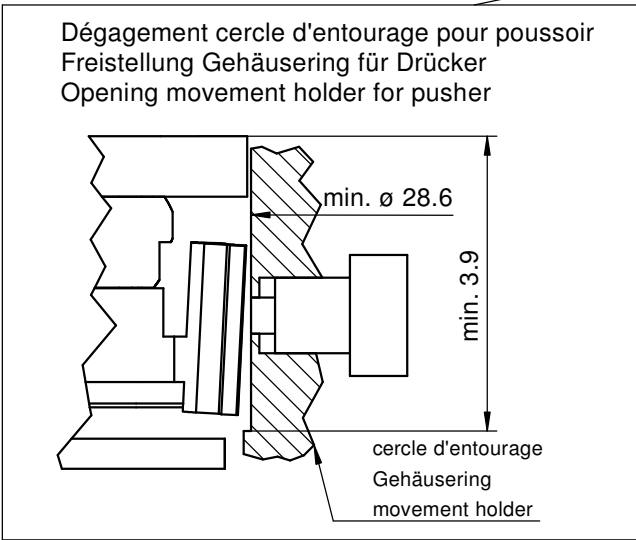
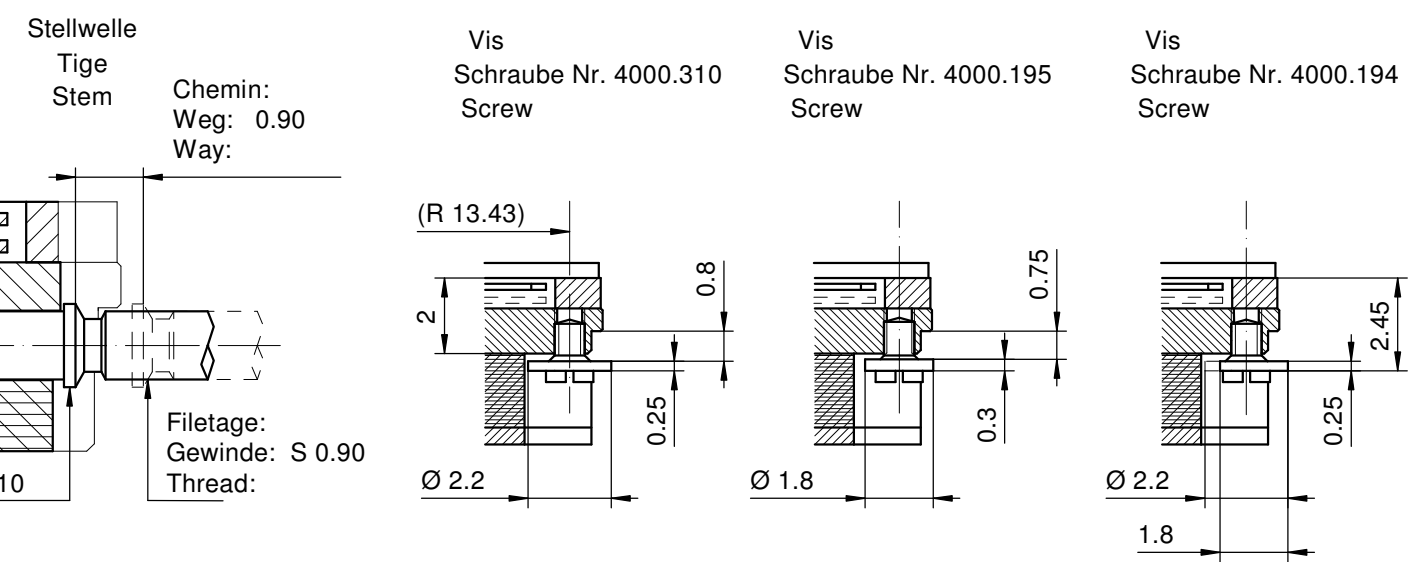
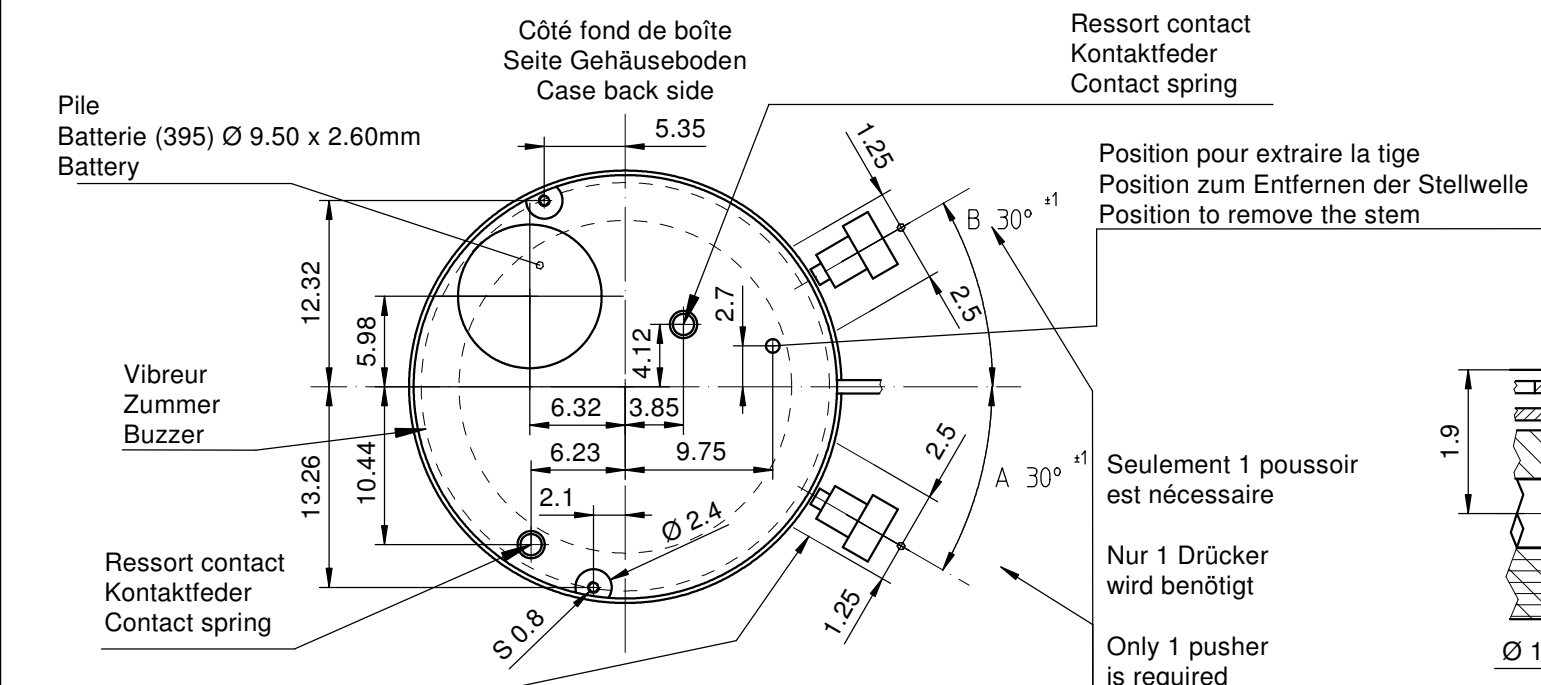

L'angle indiqué pour la direction du poussoir et la position doivent être respectés.  
Pour un angle de 0° des poussoirs A et B, voir plan 5000.345

Der angegebene Winkel für die Drückerrichtung und die Position müssen eingehalten werden.  
Für einen Drückerwinkel von 0° bei A und B, siehe Zeichnung 5000.345

The indicated angle of the pusher direction and the position must be fulfilled. For pusher angles of 0° (pusher A and B), see drawing 5000.345.

<b>Cage Urwerkgestell 12½" Frame</b>		Issued	14 Nov 2003	mk
		Modified	05 Sep 2016 ÄÄ 34777	dh
		Released	YES	
		Tolerance	+/- 20 µm	
		Scale	10 : 1 (5 : 1) (A3H)	
<b>RONDA      4120.B</b>		Sous réserve de modifications Änderungen vorbehalten Modifications reserved		
		No.	5000.322	08

Angle Winkel Angle	30°	
Ø Dp	b	
1.00	13.50	
1.10	13.50	
1.20	13.50	
1.30	13.50	
1.40	13.50	

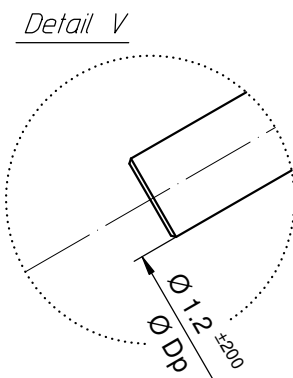
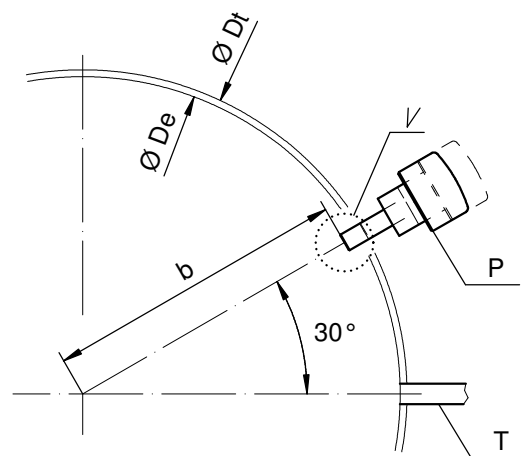

Angle Winkel Angle	0°	
Ø Dp	a	b
1.30	7.40	11.43
1.40	7.45	11.40

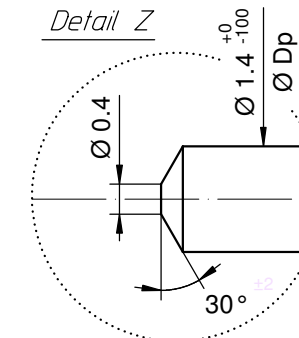
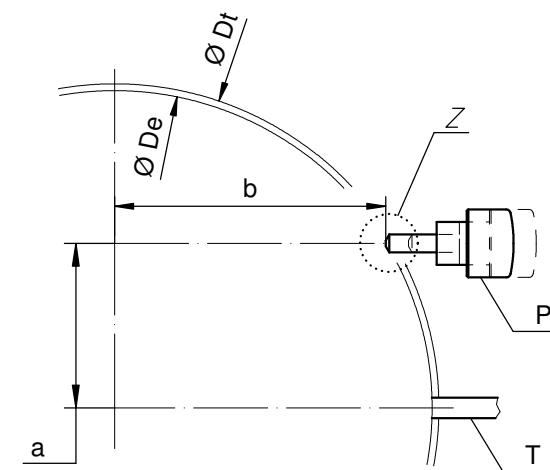

Angle Winkel Angle	20°	
Ø Dp	a	b
1.30	2.57	13.22
1.40	2.59	13.21

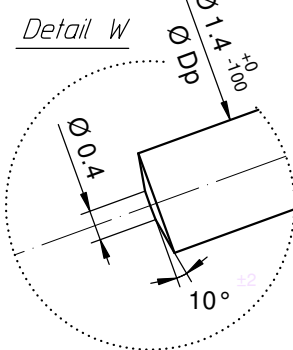
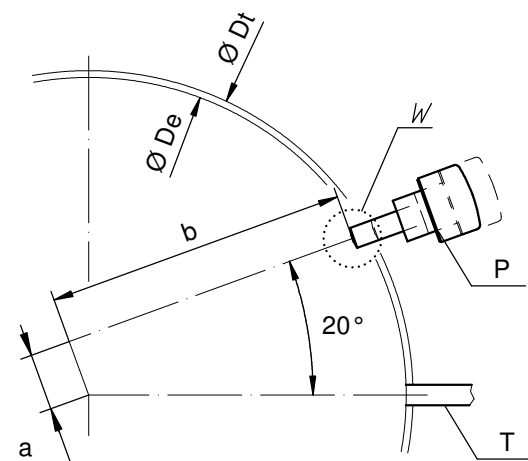

Ø De: diamètre d'encageage  
Durchmesser der Gehäusepassung  
fitting-diameter

Ø Dp: diamètre du poussoir  
Drückerdurchmesser  
pusher-diameter

Ø Dt: diamètre total  
Totaldurchmesser  
total-diameter

P: poussoir en position poussée  
Drücker in gedrückter Stellung  
pusher in pressed position

T: tige de mise à l'heure  
Stellwelle  
stem

Angle Winkel Angle	15°	
Ø Dp	a	b
1.30	3.83	12.92
1.40	3.86	12.91

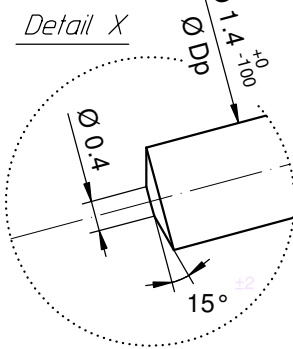
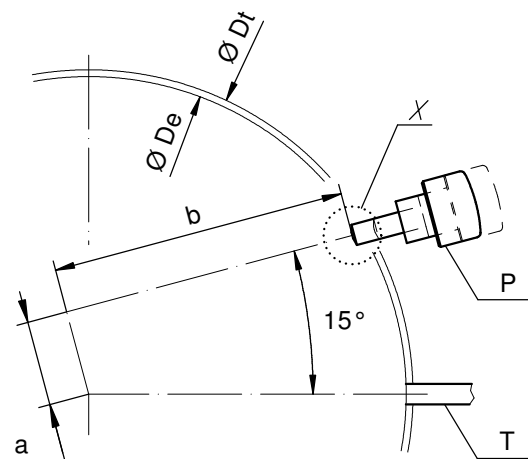

Angle Winkel Angle	10°	
Ø Dp	a	b
1.30	5.06	12.52
1.40	5.10	12.50

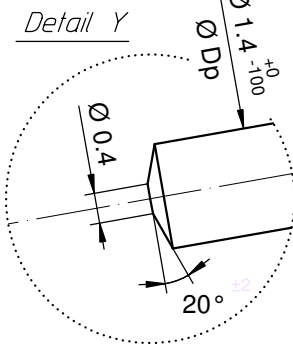
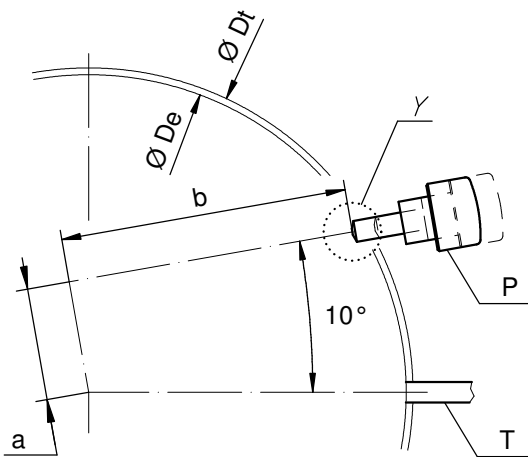

Angle des poussoirs A et B  
Winkel der Drücker A und B  
Angle of pusher A and B

RONDA 4xxx.x, 5xxx.x

Issued	06 Sep 2004	mk
Modified	30.März 2005 ÄA 1784	mk
Released	YES	
Tolerance	+/- 20 µm	
Scale	10 : 1 (5 : 1) (A3H)	
Sous réserve de modifications Änderungen vorbehalten Modifications reserved		
No.	5000.345	01