

Petite seconde
Kleine Sekunde
Small second

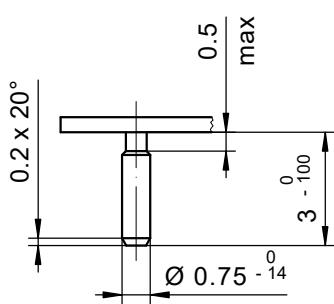

Epaisseur du cadran selon hauteur de l'aiguillage
Zifferblattdicke gemäss Zeigerwerkhöhen
Dial thickness according to hand fitting heights

Tige	Date
Stellw.	Datum
Stem	Date
3H	6H

Cadran Zifferblatt 12½" Dial

Issued	16.08.2019	dh5221
Modified	06.05.2021	dh5221
Released	YES	
Mod. No.	ÄA 43820	
Tolerance	±20 µm	
Scale	10 : 1	Page 1/1 A4

RONDA 4310.D

Sous réserve de modifications
Änderungen vorbehalten
Modifications reserved

No. 5010.841 01