

Ajustement aiguille des minutes  
Minutenzeigerpassung  
Minute hand fitting

Ajustement aiguille des secondes chrono  
Stopp-Sekundenzeigerpassung  
Chrono second hand fitting

Ajustement aiguille des heures  
Stundenzeigerpassung  
Hour hand fitting

Ajustement aiguille Zeigerpassung  
Hand fitting

Ajustement aiguille Zeigerpassung  
Hand fitting

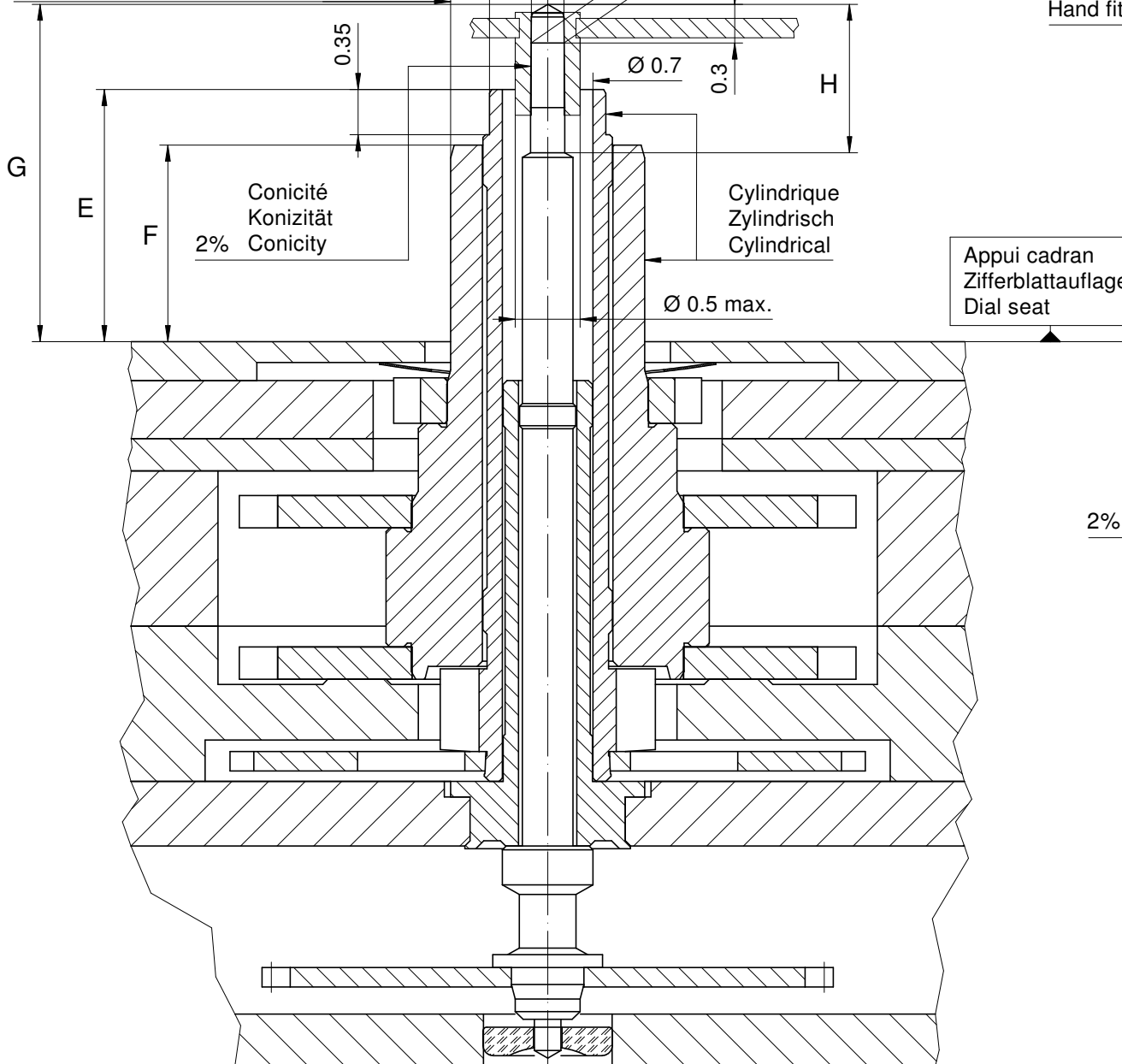

Heures / minutes / secondes chrono  
Stunden / Minuten / Stopp-Sekunden  
Hours / minutes / chrono seconds

	Aig. des sec. chrono Stopp-Sekundenzeiger Chrono second hand	Aig. des minutes Minutenzeiger Minute hand	Aig. des heures Stundenzeiger Hour hand	Aig. petite secondes Kleine Sekundenzeiger Small second hand	Aiguille compteur minute Zähler Zeiger Minute Counter hand minute	Aiguille compteur 1/10 sec. Zähler Zeiger 1/10 Sek. Counter hand 1/10 sec.	Lors de la pose d'aiguilles, le mouvement doit être soutenu. Beim Zeigersetzen muss das Werk abgestützt werden. The movement needs to be supported for hand setting.
mg max.	10	30	30	10	10	10	Masse / Masse / weight
µNm max.	0.06	0.80	0.80	0.07	0.03	0.02	Balourd / Unwucht / unbalance
gmm <sup>2</sup> max.	1.0	--	--	0.4	1.0	1.0	Inertie / Massenträgheit / Inertia
N max.	30	40	40	30	30	30	Force de chassage / Aufpresskraft / Force

\* En cas de données différentes, veuillez contacter le service après-vente \* Bei abweichenden Werten, bitte technischen Kundendienst anfragen \* In case of different values, please contact the customer service

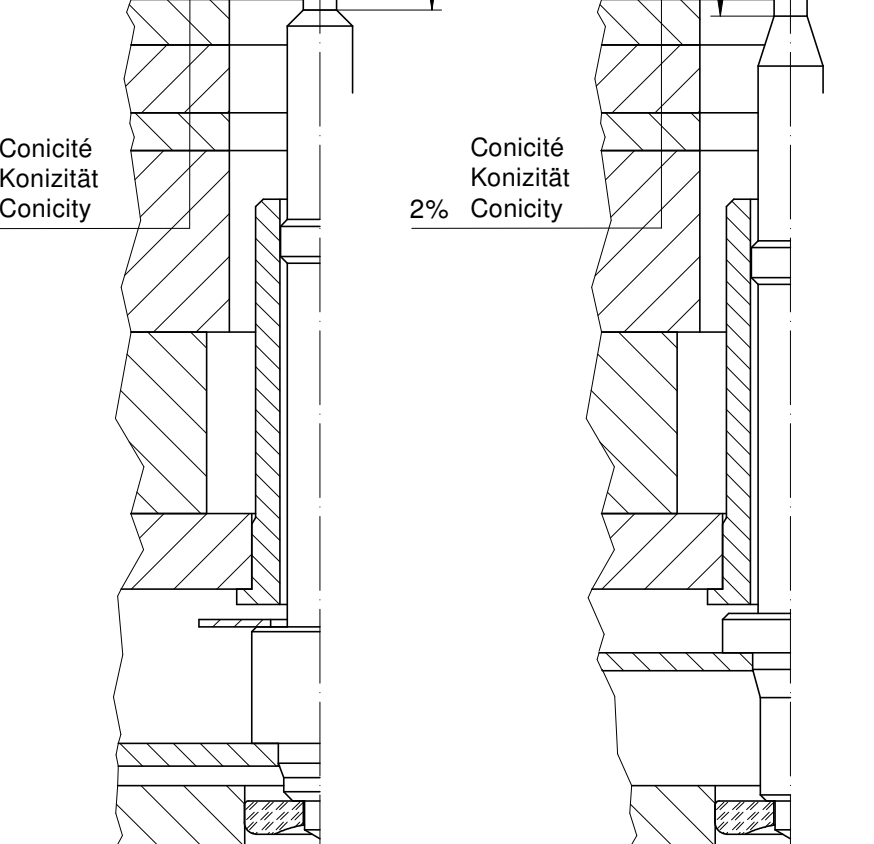
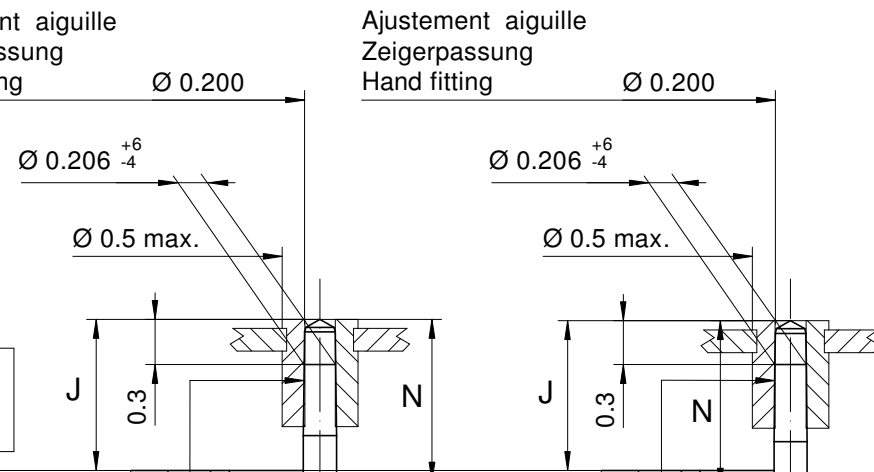

Petite seconde  
Kleine Sekunde  
Small second

Compteur 1 aiguille  
1 Zeiger Zähler  
1 Hand counter

Aiguillages Zeigerwerkhöhe Hand fitting height							
Dépassement Höhe über Zifferblattaufgabe Height over dial seat							
No	G	E	F	H	N	J	J
1	2.61	1.95	1.52	1.15	1.05	1.00	1.00
-							

Aiguillages Zeigerwerkhöhe Hand fitting height						
Peinture comprise / inkl. Farbe / Paint included						
Epaisseur maximum du cadran Maximale Zifferblattdicke Maximum dial thickness						
No	Sous l'aiguille des secondes chrono Unter Stopp-Sekundenzeiger Under chrono second hand	Sous l'aiguille des minutes Unter Minutenzeiger Under minute hand	Sous l'aiguille des heures Unter Stundenzeiger Under hour hand	Sous l'aiguille de petite seconde Unter kleine Sekundenzeiger Under small second hand	Sous l'aiguille compteur 1 aiguille Unter Zeiger 1 Zeiger Zähler Under hand 1 hand counter	Epaisseur des aiguilles Zeigerdicke Hands thickness
1	2.10	1.55	1.10	0.55	0.55	0.15
-						

Aiguillages Zeigerwerkhöhen 15 "" Hand fitting heights			
RONDA	8040.B	Issued	02 Jun 2008 mg
		Modified	15 Okt 2014 ÄÄ 13275 dh
		Released	Yes
		Tolerance	µm
		Scale	20 : 1 (A3H)
Sous réserve de modifications Änderungen vorbehalten Modifications reserved			
No.	3316.123	02	